



COMPACTGROUND

COMPACTGROUND **G15**

SMART. STABLE. INTELLIGENT.

Compact and tested substructure for the single-sided stand-mounting of PV modules on open ground

The Compact**GROUND G15** is a south-facing open ground system with an incline of 15° and a floor spacing of up to 16.0". The aerodynamic design boasts excellent structural properties and requires considerably less ballast than other systems on the market.

AEROCOMPACT®



Installation is performed without piling instruments or big machine deployment. The Compact**GROUND G15** is ballasted with weights, but can also alternatively be fixed with the grounding pins option.

As one of the quickest open ground systems in the industry to install and with the capability of loading up to 700 kWp in one truck, the Compact**GROUND G15** not only offers the best installation times and transport costs, but also a considerable price advantage. Thanks to these distinctive product characteristics, the system is also especially well-suited to temporary project installations or small systems from 2 kWp and upwards.

Due to the special “spring effect” of the legs, the substructure adjusts optimally to the conditions of the surface structure.

The system was tested and approved by TÜV Rheinland in accordance with UL 2703. The wire management solution for the string-wiring of module rows is UL-certified and available as an accessory with the substructure.

The Compact**GROUND G15** system is stored in our 3D engineering software Aero**TOOL**. The AEROCOMPACT® customer center is able to issue clear and competent project reports based on empirical data (wind load, snow load, structural analysis).

With only three main components, the Compact**GROUND G15** achieves an exceptional price-performance ratio. In addition to the attractive system price, the simple installation of the innovative system saves time and resources.

G15 - 21.9" Inter-row spacing

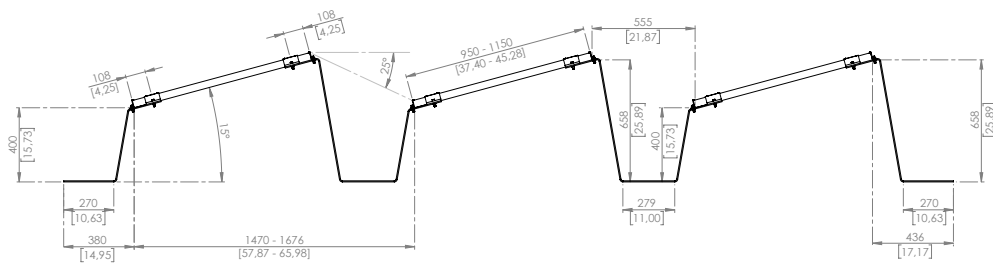

TECHNICAL DATA

Description	Aerodynamic installation system for the stand-mounting of framed PV modules on open ground.
Scope of use	On grassland and farmland, as well as on sand, gravel, grit, concrete, or asphalt
Module dimensions	37.4" to 45.3" x 59.0" to 88.6" (width x length)
Installation angle	15°, unilateral
Row spacing	CompactGROUND G15
Distance from the floor surface	CompactGROUND G15: Approx. 16.0"
Distance from roof edge	-
Max. building height	-
Max. roof pitch	Up to 10° possible without ground anchors; over 10° only with ground anchors
Max. field size	12 x 20 rows; 240 modules
Min. field size	3 rows for every 2 modules; or 2 rows for every 3 modules
Wind load	Suction load up to 2.4 kN/m ²
Snow load	Pressure load of the CompactGROUND G15 Standard up to 1.6 kN/m ² Pressure load of the CompactGROUND G15 Alpin up to 2.4 kN/m ²
Design/stability verification	Software-supported based on wind tunnel analyses
On-site requirements	Sufficient load-bearing capacity and compressive strength of the ground must be ensured on site. The general terms and conditions, terms of warranty, and the user agreement apply.
Module approval	The list of approved modules is provided by AEROCOMPACT®; individual approvals through the module manufacturer
Components	Module clamps with grounding pins, open ground brackets, ballast stones; optional ballast trays, ground anchors
Materials	Bearing connecting parts made from aluminum EN AW 6060 T64; module clamps made from aluminum EN AW 6063 T66; screws made from stainless steel A2-70; ballast trays made from steel with aluminum-zinc coating; ground anchors made from cast aluminum

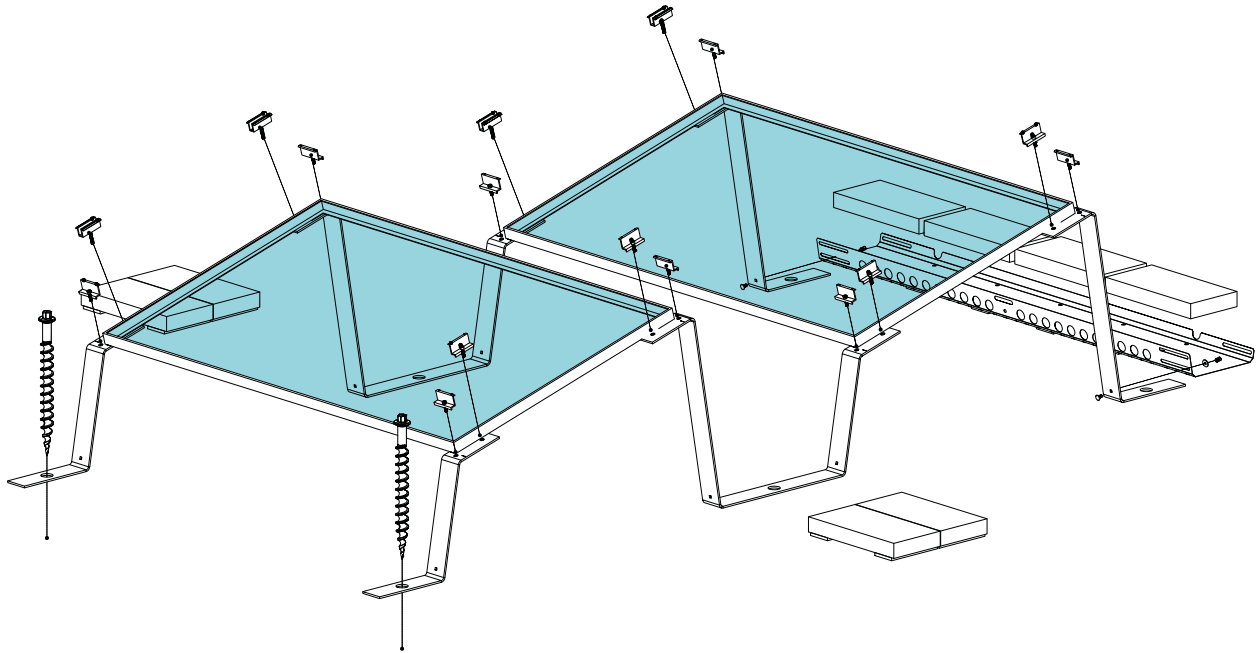

- › **Module clamps with grounding pins**
- › **Grounding screw fixing option**
- › **Very low transport costs**
- › **Installation without piling implements or big machine deployment**
- › **Suitable for temporary project installations**
- › **Structurally optimized system**
- › **Minimum order quantity only 2 kWp**
- › **Quickest open ground installation**
- › **UL-certified wiring management**
- › **TÜV-certified as per UL 2703**
- › **Wind tunnel-tested**
- › **Engineered in Europe**
- › **General building inspectorate approval applied for**
- › **25 years product warranty**



< **Scan QR code to watch installation video**

AEROCOMPACT®

Headquarters USA

Aerocompact Inc. // 901A Matthews Mint Hill Road // Matthews, NC 28105, USA

Phone: +1 800 578 0474 // E-mail: office.us@aerocompact.com

www.aerocompact.com